

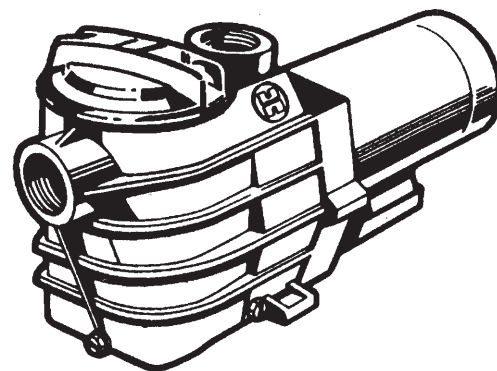

Super II™ Pump

Your Hayward self-priming centrifugal pump has been quality-built and engineered to give you many years of efficient, dependable, corrosion-free service.

The advanced design reduces operation and maintenance to simple, common-sense procedures.



IMPORTANT SAFETY INSTRUCTIONS

When installing and using this electrical equipment, basic safety precautions should always be followed, including the following: Failure to follow instructions may result in injury.

READ AND FOLLOW ALL INSTRUCTIONS

1. **WARNING** - To reduce risk of injury, do not permit children to use this product unless they are closely supervised at all times.
2. **CAUTION** - This pump is U.L. listed for permanently installed pools and may also be used with hot tubs and spas if so marked. It is not U.L. listed for storable pools. A permanently installed pool is constructed in or on the ground and cannot be readily disassembled for storage. A storable pool is constructed so that it may be readily disassembled for storage and reassembled to its original integrity.
3. If installed within an outer enclosure or beneath the skirt of a hot tub or spa, adequate ventilation and free circulation of air must be provided to prevent overheating of the motor.
4. Use motor bonding lug to connect the motor with other bonding parts using a #8 AWG conductor as required by electrical codes. **NOTE:** If your pump is equipped with a 3 ft. (1 m) cord and twist lock plug, items 5 through 8 apply.
5. **WARNING** - Risk of Electric Shock. Connect only to a grounding-type receptacle protected by a ground fault circuit interrupter (GFCI). Contact a qualified electrician if you cannot verify that the receptacle is protected by a GFCI.
6. Do not bury cord. Locate cord to minimize abuse from lawn mowers, hedge trimmers, and other equipment.
7. **WARNING** - To reduce the risk of electric shock, replace damaged cord immediately.
8. **WARNING** - To reduce the risk of electric shock, do not use extension cord to connect unit to electric supply; provide a properly located outlet.

SAVE THESE INSTRUCTIONS

GENERAL TIPS ON PUMP INSTALLATION

Locate the pump as close to pool as practical and run suction line as direct as possible. This cuts down on friction loss through pipe and fittings.

Never overtighten pipe connections—use only pipe sealants formulated specifically for plastics, i.e., Teflon tape, Permatex No. 2, etc.

Suction line should have continuous slope from lowest point in line. Make sure suction joints are tight. Suction pipe should be as large or larger than discharge pipe.

Damp, non-ventilated locations should be avoided. Motors require free circulation of air to aid in cooling.

Insure that the electrical supply available agrees with the motor's voltage, phase and cycle, and that wire size is adequate for the HP (KW) rating and distance from power source. Motor must always be properly grounded. If cord connected, use only a properly grounded outlet. Electrical circuits must be protected by proper size ground fault circuit interrupter (GFCI) as required by applicable

electrical codes. All electrical wiring must be performed by qualified personnel, and must conform to local codes and regulations.

STARTING AND PRIMING INSTRUCTIONS

Fill strainer housing with water to suction pipe level. Never operate the pump without water. Water acts as a coolant and lubricant for the mechanical shaft seal.

Open all suction and discharge lines and valves, as well as air bleed (if available) on filter. (The air that is to be displaced from the suction line must have some place to go.) **Caution: All suction and discharge valves must be open when starting the system. Failure to do so could cause severe personal injury and/or property damage.**

Turn on power and allow a reasonable time for priming. Five minutes is not unreasonable. (Priming time depends on suction lift and horizontal length of suction piping). If the pump will not start, or will not prime, see TROUBLE SHOOTING GUIDE on back page.

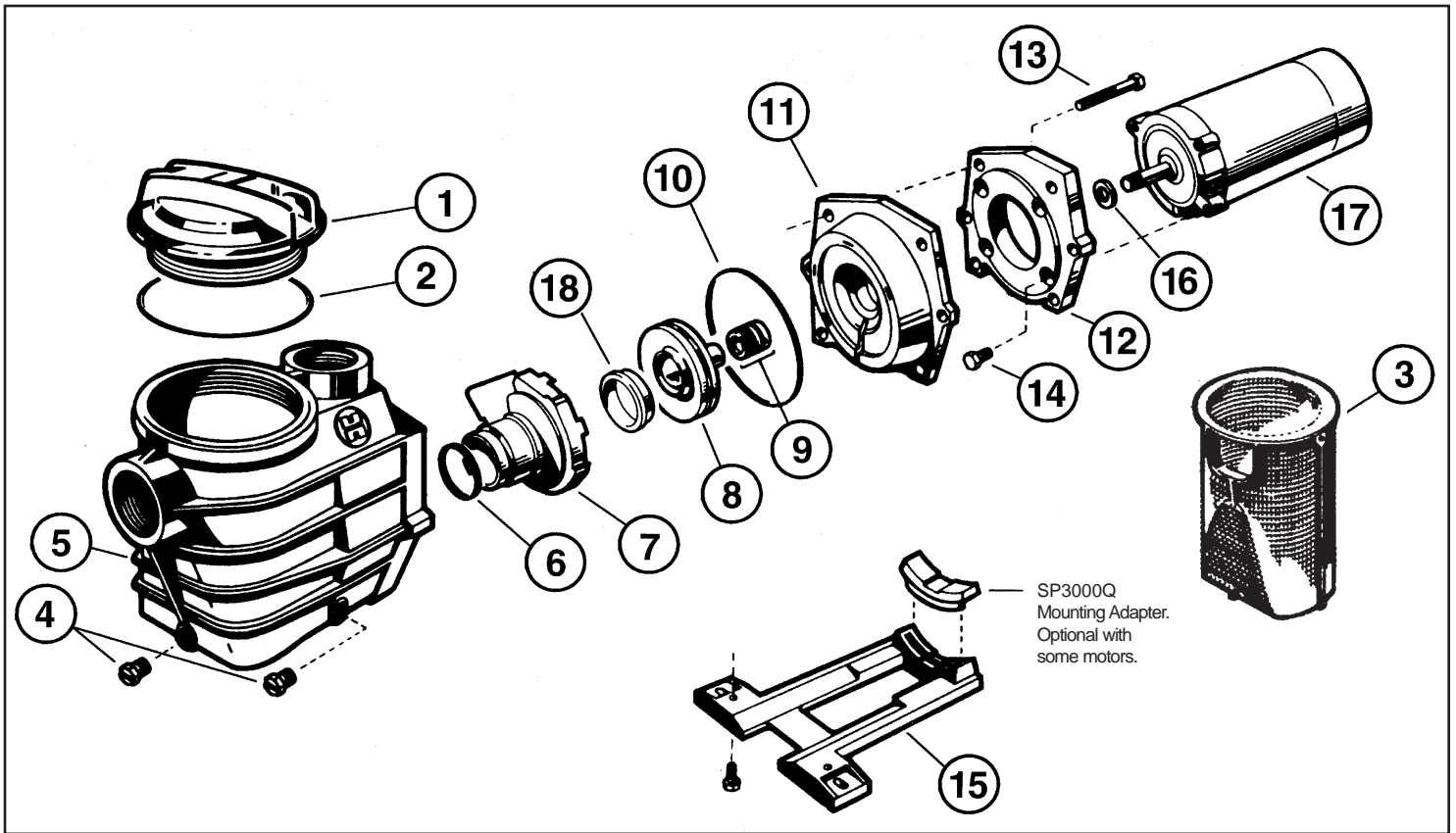

REF. NO.	DESCRIPTION	NO. REQ'D.	PART NUMBER					
			MODEL SP3005X7AZ	MODEL SP3007X10AZ	MODEL SP3010X15AZ	MODEL SP3015X20AZ	MODEL SP3020X25AZ	MODEL SP3025X30AZ
1	Strainer Cover	1	SPX3100D	SPX3100D	SPX3100D	SPX3100D	SPX3100D	SPX3100D
2	Strainer Cover O-Ring	1	SPX3000S	SPX3000S	SPX3000S	SPX3000S	SPX3000S	SPX3000S
3	Basket	1	SPX3000M	SPX3000M	SPX3000M	SPX3000M	SPX3000M	SPX3000M
4	Drain Plug w/Gasket	2	SPX1700FG	SPX1700FG	SPX1700FG	SPX1700FG	SPX1700FG	SPX1700FG
5	Pump/Strainer Housing	1	SPX3100AAZ	SPX3100AAZ	SPX3120AAZ	SPX3120AAZ	SPX3120AAZ	SPX3120AAZ
6	Diffuser Gasket	1	SPX1600R	SPX1600R	SPX1600R	SPX1600R	SPX1600R	SPX1600R
7	Diffuser	1	SPX3000BN	SPX3000BN	SPX3000BN	SPX3021B	SPX3021B	SPX3021B
8	Impeller - 60 cycle single phase	1	SPX3005C	SPX3007C	SPX3010C	SPX3016C	SPX3021C	SPX3026C
	Impeller - 50 cycle three phase	1	SPX3007C (SP3005X751)	SPX3010C (SP3007X1051)	SPX3016C (SP3010X1551)	SPX3021C (SP3015X2051)	SPX3026C (SP3020X2551)	SPX3031C (SP3025X10G51)
9	Seal Assembly	1	SPX1600Z2	SPX1600Z2	SPX1600Z2	SPX1600Z2	SPX1600Z2	SPX1600Z2
10	Housing Gasket	1	SPX3000T	SPX3000T	SPX3000T	SPX3000T	SPX3000T	SPX3000T
11	Seal Plate	1	SPX3020E	SPX3020E	SPX3020E	SPX3020E	SPX3020E	SPX3020E
12	Motor Mounting Plate	1	SPX3000F	SPX3000F	SPX3000F	SPX3000F	SPX3000F	SPX3000F
13	Housing Cap Screw	6	SPX1600Z4	SPX1600Z4	SPX1600Z4	SPX1600Z4	SPX1600Z-4	SPX1600Z4
14	Motor Cap Screw	4	SPX0125Z4	SPX0125Z4	SPX0125Z4	SPX0125Z4	SPX0125Z4	SPX0125Z4
15	Mounting Bracket With Adapter & Screws	1	SPX3000GA	SPX3000GA	SPX3000GA	SPX3000GA	SPX3000GA	SPX3000GA
16	Slinger	1	SPX0125F	SPX0125F	SPX0125F	SPX0125F	SPX0125F	SPX0125F
17	Motor — 60 cycle single phase	1	SPX01605Z1M	SPX01607Z1M	SPX01610Z1M	SPX01615Z1M	SPX01620Z1M	SPX01625Z1M
	Motor — 50 cycle single phase	1	SPX0130Z1CM (SP3005X751)	SPX0135Z1CM (SP3007X1051)	SPX0140Z1CM (SP3010X1551)	SPX0150Z1CM (SP3015X2051)	SPX0155Z1CM (SP3020X2551)	SPX0160Z1CG (SP3025X30G51)
18	Impeller Ring		For Impeller SPX3005C, SPX3007C, SPX3010C, USE SPX3005R; For Impeller SPX3016C or above, use SPX3021R.					

MAINTENANCE

1. Clean strainer basket regularly. Do not strike basket to clean. Inspect strainer cover O-ring regularly and replace as necessary.
2. Hayward pumps have self-lubricating motor bearings and shaft seals. No lubrication is necessary.
3. Keep motor clean. Insure air vents are free from obstruction.
4. Occasionally, shaft seals become damaged or worn and must be replaced. See instructions.

STORAGE/WINTERIZING

1. Drain pump by removing drain plug(s) and store in strainer basket.
2. Disconnect electrical wires and pipe connections, and store pump in dry, well-ventilated room. Or: Disconnect electrical wires. Remove six (6) bolts holding bracket and motor assembly to strainer housing and store assembly in a dry, well-ventilated room. Protect remaining strainer housing assembly from the elements by covering.

NOTE: Before reactivating pump, thoroughly clean and remove scale, dirt, etc.

SEAL CHANGE INSTRUCTIONS

SP3000 SERIES GENERAL

*Exercise extreme care in handling and installing the new seal and ceramic seat assembly.
The lapped and polished surfaces may easily be damaged by dirt or scratching.*

For safety, all service must be performed with **all power shut off**.

REMOVING THE MOTOR ASSEMBLY

1. Remove the six (6) 3/8" x 2" **hex head bolts** which hold the motor assembly to the pump/strainer housing.
2. Slide the motor assembly out of the pump/strainer housing, exposing the diffuser. Pull the diffuser off of the seal plate, exposing the impeller. (The diffuser may remain in the pump/strainer housing. To remove, pull it straight out of the strainer housing.)

REMOVING THE IMPELLER (see note)

3. Remove the motor end cover by removing the 2 screws.*
4. To prevent motor shaft from turning, **carefully** slide a 7/16" wrench between the capacitor and the protector switch and rotate the impeller so the wrench fits over the 2 flats on the motor shaft.
5. Rotate the impeller counterclockwise and remove. The spring portion of the seal assembly is now exposed. Note carefully the position of the spring seal, and remove it.

NOTE: Replace motor cover to protect delicate motor parts.

REMOVING THE CERAMIC SEAT

6. Remove the seal plate. Note the notch on the top of the plate and the mating lug on the top of the motor mounting bracket.
 7. Press the ceramic seat with O-ring out of the seal plate. If tight, use a small screwdriver to tap seat out.
- STOP**—Clean all recesses and parts to be reassembled. Inspect gaskets and replace if necessary.

SEAL INSTALLATION

8. Clean and lightly lubricate the impeller hub and seal recess in the seal plate with a dilute solution of non-granulated liquid-type soap.
9. Gently wipe the black, polished surface of the spring seal assembly with a clean, soft, cotton cloth. Press the spring seal assembly onto the impeller hub—black polished surface facing away from the impeller.
10. Gently wipe the polished face of the ceramic seat with a soft, cotton cloth. Lubricate the O-ring on the ceramic seat and press it firmly and evenly into the recess of the seal plate—polished side facing out.
11. Place the seal plate onto the motor mounting bracket aligning the positioning lug and guide.

REPLACING THE IMPELLER AND DIFFUSER

12. Screw the impeller onto the motor shaft in a clockwise direction. Tighten snugly by holding motor shaft with wrench.
13. Place the diffuser over the impeller onto the seal plate, fitting positioning lug between the two guides.

REPLACING THE MOTOR ASSEMBLY

14. Slide the motor assembly, with the diffuser in place, into pump/strainer housing, being careful not to dislodge the diffuser.
15. Fasten assembly to housing using the six (6) 3/8" x 2" bolts. (Be sure housing gasket is in place.) Tighten alternately and evenly.

**For motors without removable end cover - pry off cap at rear center of motor. Place large screwdriver in slot end of shaft to keep shaft from turning.*

NOTE: For models equipped with Impeller Ring - remove impeller ring from front hub of impeller. When reassembling, be sure to replace it on impeller hub, larger end facing diffuser, before placing diffuser over the impeller.

TROUBLE SHOOTING GUIDE

A. MOTOR WON'T START

1. Check for improper or loose connections, open switches or relays, blown circuit breakers or fuses.
2. Manually check rotation of motor shaft for free movement and lack of obstruction.

B. MOTOR CUTS OUT—Check for:

1. Wiring, loose connections, etc.
2. Low voltage at motor (frequently caused by undersized wiring).
Binding and overload. (Amperage reading)

NOTE: Your Hayward pump motor is equipped with Automatic Thermal Overload Protection. The motor will automatically shut off, under normal conditions, before heat damage build-up, due to an improper operating condition, can occur. The motor will auto-restart when safer heat level is reached.

C. MOTOR HUMS, BUT DOES NOT START—

Check for:

1. Governor stuck in open position. (Not applicable to 3 HP motor).
2. Open capacitor. (Not applicable to 3 HP motor).

D. PUMP WON'T PRIME

1. Make sure pump/strainer housing is filled with water and that cover gasket is clean and properly seated. Tighten hand nuts.
2. Make sure all suction and discharge valves are open and unobstructed, and that pool water level is above all suction openings.
3. Block off suction as close to pump as possible and determine if pump will develop a vacuum.
 - a. If pump does not develop a vacuum and pump has sufficient "priming water":
 1. Tighten all bolts and fittings on suction side.
 2. Check voltage to make sure pump is up to speed.
 3. Open pump and check for clogging or obstruction.
 4. Remove and replace shaft seal.

1. Tighten all bolts and fittings on suction side.
2. Check voltage to make sure pump is up to speed.
3. Open pump and check for clogging or obstruction.
4. Remove and replace shaft seal.

- b. If pump develops a vacuum, check for blocked suction line or strainer, or air leak in suction piping.

E. LOW FLOW—Generally, check for:

1. Clogged or restricted strainer or suction line; undersized pool piping.
2. Plugged or restricted discharge line of filter (high discharge gauge reading).
3. Air leak in suction (bubbles issuing from return fittings).
4. Pump operating underspeed (low voltage).
5. Plugged or restricted impeller.

F. NOISY PUMP—Check for:

1. Air leak in suction causing rumbling in pump.
2. Cavitation due to restricted or undersized suction line and unrestricted discharge lines. Correct suction condition or throttle discharge lines, if practical.
3. Vibration due to improper mounting, etc.
4. Foreign matter in pump housing.
5. Motor bearings made unserviceable by wear, rust, or continual overheating.

SERVICE & REPAIRS

Consult your local authorized Hayward dealer or service center. No pumps or motors may be returned directly to the factory without the expressed written authorization of Hayward Pool Products, Inc.

ELECTRICAL GUIDE

MOTOR		VOLTS			CIRCUIT BREAKER RATINGS-AMPS			RECOMMENDED WIRE SIZE 0-50'		
KW	HP	50 CYCLE 1 PHASE	50 CYCLE 3 PHASE	60 CYCLE 1 PHASE	50 CYCLE 1 PHASE	50 CYCLE 3 PHASE	60 CYCLE 1 PHASE	50 CYCLE 1 PHASE	50 CYCLE 3 PHASE	60 CYCLE 1 PHASE
3/4	0.55	110/220	---	115/230	15/10	---	15/10	14/14	---	14/14
1	0.75	110/220	---	115/230	20/10	---	20/10	12/14	---	12/14
1-1/2	1.10	110/220	220-240/380-415	115/230	30/15	10/10	30/15	10/14	14/14	10/14
2	1.55	220	220-240/380-415	115/230	---	10/10	30/15	---	14/14	10/14
2-1/2	1.88	---	---	230	---	---	15	---	---	14
3	2.20	---	220-240/380-415	230	---	15/10	20	---	14/14	12



HAYWARD POOL PRODUCTS, INC.

Hayward Pool Products, Inc.
900 Fairmount Avenue
Elizabeth, NJ 07207

Hayward Pool Products, Inc.
2875 Pomona Boulevard
Pomona, CA 91768

Hayward Pool Products Canada
2880 Plymouth Drive
Oakville, Ontario L6H 5R4

Hayward Pool Products Europe
ZA del'Observatoire
2, Avenue des Chaumes
78182 St. Quentin en Yvelines Cedex
France