

HAYWARD® Pool Products

One source. Every pool.

OWNER'S MANUAL

INSTALLATION, OPERATION & PARTS

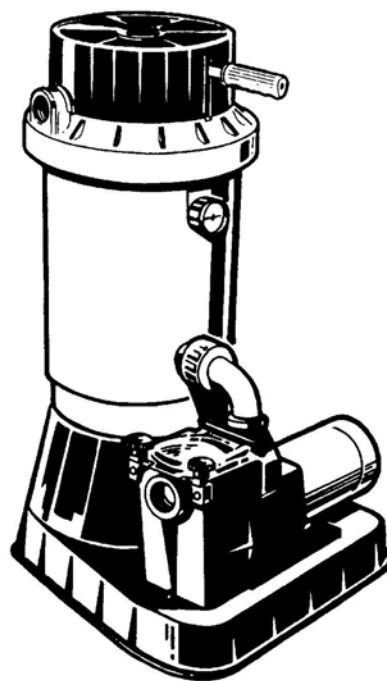

MODELS: EC65A, EC75A

PERFLEX® SERIES Extended Cycle Basic FILTER Units

Basic safety precautions should always be followed, including the following: Failure to follow instructions can cause severe injury and/or death.

⚠ This is the safety-alert symbol. When you see this symbol on your equipment or in this manual, look for one of the following signal words and be alert to the potential for personal injury.

⚠ **WARNING** warns about hazards that **could** cause serious personal injury, death or major property damage and if ignored presents a potential hazard.

⚠ **CAUTION** warns about hazards that **will** or **can** cause minor or moderate personal injury and/or property damage and if ignored presents a potential hazard. It can also make consumers aware of actions that are unpredictable and unsafe.

The **NOTICE** label indicates special instructions that are important but not related to hazards.

SAVE THIS INSTRUCTION MANUAL

USE ONLY HAYWARD GENUINE REPLACEMENT PARTS

THIS PAGE IS INTENDED TO BE BLANK

USE ONLY HAYWARD GENUINE REPLACEMENT PARTS



⚠ - WARNING - Read and follow all instructions in this owner’s manual and on the equipment. Failure to follow instructions can cause severe injury and/or death.

⚠ WARNING – Suction Entrapment Hazard.

Suction in suction outlets and/or suction outlet covers which are, damaged, broken, cracked, missing, or unsecured can cause severe injury and/or death due to the following entrapment hazards:



Hair Entrapment- Hair can become entangled in suction outlet cover.

Limb Entrapment- A limb inserted into an opening of a suction outlet sump or suction outlet cover that is damaged, broken, cracked, missing, or not securely attached can result in a mechanical bind or swelling of the limb.

Body Suction Entrapment- A negative pressure applied to a large portion of the body or limbs can result in an entrapment.

Evisceration/ Disembowelment - A negative pressure applied directly to the intestines through an unprotected suction outlet sump or suction outlet cover which is, damaged, broken, cracked, missing, or unsecured can result in evisceration/ disembowelment.

Mechanical Entrapment- There is potential for jewelry, swimsuit, hair decorations, finger, toe or knuckle to be caught in an opening of a suction outlet cover resulting in mechanical entrapment.

⚠ WARNING - To Reduce the risk of Entrapment Hazards:

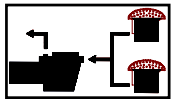

- o When outlets are small enough to be blocked by a person, a minimum of two functioning suction outlets per pump must be installed. Suction outlets in the same plane (i.e. floor or wall), must be installed a minimum of three feet (3') [1 meter] apart, as measured from near point to near point.
- o Dual suction fittings shall be placed in such locations and distances to avoid “dual blockage” by a user.
- o Dual suction fittings shall not be located on seating areas or on the backrest for such seating areas.
- o Never use Pool or Spa if any suction outlet component is damaged, broken, cracked, missing, or not securely attached.
- o Replace damaged, broken, cracked, missing, or not securely attached suction outlet components immediately.
- o In addition two or more suction outlets per pump installed in accordance with latest NSPI, IAF Standards and CPSC guidelines, follow all National, State, and Local codes applicable.
- o Installation of a vacuum release or vent system, which relieves entrapping suction, is recommended.

⚠ WARNING – Failure to remove pressure test plugs and/or plugs used in winterization of the pool/spa from the suction outlets can result in an increase potential for suction entrapment as described above.

⚠ WARNING – Failure to keep suction outlet components clear of debris, such as leaves, dirt, hair, paper and other material can result in an increase potential for suction entrapment as described above.

⚠ WARNING – Suction outlet components have a finite life, the cover/grate should be inspected frequently and replaced at least every ten years or if found to be damaged, broken, cracked, missing, or not securely attached.

⚠ CAUTION – Components such as the filtration system, pumps and heater must be positioned so as to prevent their being used as means of access to the pool by young children.

⚠ WARNING – Never operate or test the circulation system at more than 40 PSI.

⚠ CAUTION – All electrical wiring MUST be performed by a qualified professional, and MUST conform to local codes and regulations.

⚠ WARNING – Never change the filter control valve position while the pump is running.



⚠ WARNING – Hazardous Pressure. Pool and spa water circulation systems operate under hazardous pressure during start up, normal operation, and after pump shut off. Stand clear of circulation system equipment during pump start up. Failure to follow safety and operation instructions could result in violent separation of the pump housing and cover, and/or filter housing and clamp due to pressure in the system, which could cause property damage, severe personal injury, or death. Before servicing pool and spa

water circulation system, all system and pump controls must be in off position and filter manual air relief valve must be in open position. Before starting system pump, all system valves must be set in a position to allow system water to return back to the pool. Do not change filter control valve position while system pump is running. Before starting system pump, fully open filter manual air relief valve. Do not close filter manual air relief valve until a steady stream of water (not air or air and water) is discharged.



⚠ WARNING – Separation Hazard. Failure to follow safety and operation instructions could result in violent separation of pump and/or filter components. Strainer cover must be properly secured to pump housing with strainer cover lock ring. Before servicing pool and spa circulation system, filters manual air relief valve must be in open position. Do not operate pool and spa circulation system if a system component is not assembled properly, damaged, or missing.



⚠ WARNING – Electrical Ground motor before connecting to electrical power supply. Failure to ground pump motor can cause serious or fatal electrical shock hazard.

⚠ WARNING – Do NOT ground to a gas supply line.

USE ONLY HAYWARD GENUINE REPLACEMENT PARTS

⚠ WARNING – To avoid dangerous or fatal electrical shock, turn OFF power to motor before working on electrical connections.

⚠ WARNING – Failure to bond pump to pool structure will increase risk for electrocution and could result in injury or death. To reduce the risk of electric shock, see installation instructions and consult a professional electrician on how to bond pump. Also, contact a licensed electrician for information on local electrical codes for bonding requirements.

The Hayward-Perflex is a high performance swimming pool filter. The EC65AC filter has an output rating of 3,240 gallons (12.2 KL) per hour. The EC75AC filter has an output rating of 4800 gallons (18.0 KL) per hour. Manufactured from durable, corrosion-proof materials, the filter can be combined on a strong, molded mounting base. The filters are designed for continuous operation, for installation up to 2 feet above the pool water line. It may be used on fresh or salt water swimming pools.

The Perflex filter uses diatomite filter powder (commonly called D.E.). D.E. is the most efficient dirt remover known. It is normally fed into the system through the skimmer when the filter is initially started; then drained from the filter when it can no longer efficiently remove dirt from the water. Through the Perflex's exclusive "BUMP" action, the D.E. is periodically regenerated and the filter cycle extended without changing the powder. When the filter powder is totally used, the "BUMP" action makes it possible to drain the used diatomite without backwashing or dismantling the filter.

PUMP SELECTION

To power your Perflex filter, select a continuous duty pump designed for swimming pool service. The pump mounting bracket (EC65BLP) and hardware purchased separately for the filter will readily accept most units.

It is important to determine whether the pump will be located above or below the normal pool water line. If the pump is going above the water line, a self-priming centrifugal pump must be used. Self-priming pumps can lift water from a lower level and prime automatically. There is another type of pump simply called the centrifugal. Unlike self-priming centrifugals which can lift water from a lower level, a centrifugal must be located below the water line for dependable priming.

Select a pump with an output rating of between 30 and 100 GPM (114-380 LPM).

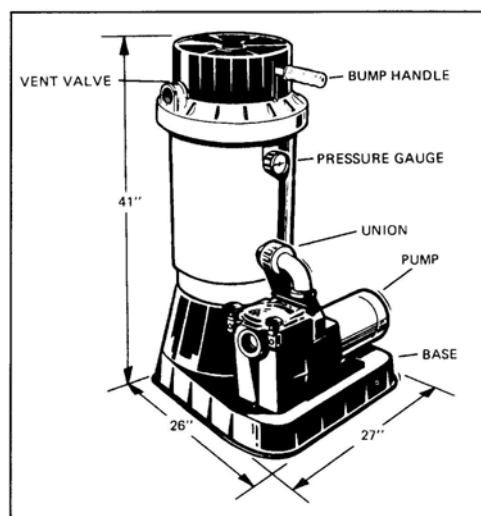

SYSTEM LOCATION

1. Though the system is designed for outdoor use, it is advisable to protect electrical components from the weather. Select a well-drained area, one that will not flood when it rains.
2. For best pump performance, locate the system above the pool water line, a Super Pump[®], Super II[™] pump, Max-Flo or TriStar[™] pump is required and can be raised two feet above the water line.

3. Set the mounting platform level. Keep the filter bump handle, drain outlet, and pressure gauge accessible for convenient operation. There is an alternate bump handle location on the other side of the filter outlet. Instructions for changing the handle position are covered later.
4. Position the system so that the filter tank can drain by gravity.

PLUMBING & INSTALLATION

1. Use 1-1/2" I.D. flexible plastic pipe, or hose, joined with insert fittings and stainless steel clamps. If rigid return piping is used, installation of a piping union is recommended for ease of future servicing.
2. All plumbing connections on the system are 1-1/2" N.P.T. When making connections, use plastic male-end adapters. Apply three turns of Teflon tape or plastic pipe sealant compatible with ABS to the male threads. Screw the fitting into the thread hand tight; then, using a wrench, tighten one more full turn. Additional tightening is unnecessary-and-could result in damage to components.
3. Tighten pump base mounting bolts, if loose.
4. Securely *hand tighten* the union nut between the filter and pump.
5. Connect the pool suction plumbing between the skimmer, pool outlet, and the pump.
6. Connect the pool return (inlet) plumbing
7. If the pressure gauge is not installed, apply Teflon tape to the gauge threads, and carefully screw the gauge into the threaded hole in the side of the filter body.
8. A drain plug, with gasket, is furnished with each filter and is all that is needed for complete filter draining. If desired however, drain piping may be extended from the filter by using the optional Drain Valve Kit (Model SP0723) and an appropriate length of 1-1/2" pipe. Piping must slope away from the filter so the tank can drain by gravity.
9. All electrical connections should be made in accordance with applicable electrical codes.
10. Check for joint leaks before operating system.
11. Refer to pump instruction booklet for pump information.

USE ONLY HAYWARD GENUINE REPLACEMENT PARTS

BEFORE STARTING THE FILTER

1. Obtain a supply of operating chemicals, D.E., and a pool test kit. Use only the swimming pool grades of D.E., such as:

| | |
|---------------|-------------------------------------|
| CELATOM | Eagle-Picher Industries, Inc. |
| AQUA-CEL | Johns-Manville Products Corporation |
| DICALITE 4200 | Grefco Inc. |
| WITCO | Witco Corporation |

2. Superchlorinate the pool water by adding unstabilized granular or liquid chlorine. Stabilized forms of chlorine are recommended for normal daily use after the initial clean up of the water. Follow chemical manufacturer's recommendations for superchlorination and daily use.

STARTING THE FILTER

Close the filter drain and the vent valve.



CAUTION: All suction and discharge valves must be open when starting the pump. Failure to do so could cause severe personal injury and/or property damage.

Prime and start the pump following the manufacturer's instructions. Air trapped in the system will automatically vent to the pool. When there is a steady flow of water returning to the pool, the filter is ready for precoat. **DO NOT** operate the filter for more than one minute without the precoat charge.

PRECOATING

For the EC65A Scoop 6 lbs. (2.7 kgs.) of diatomite into the system through the skimmer as fast as the plumbing will take it. For the EC75A Scoop 7 lbs. (3.2 kgs.) of diatomite into the system through the skimmer as fast as the plumbing will take it. Note and record the pressure gauge reading after the diatomite has been added. This is the "precoat pressure."

FILTERING

Filtration starts as soon as the filter has been precoated. As the filter removes dirt from the pool water, the accumulated dirt causes a resistance to flow. As a result, the gauge pressure will rise and the flow will decrease. When the pressure rises 7-10 psi (.49-.70 Bar) above the precoat pressure, regenerate the filter.

REGENERATION (Extending the Cycle)

Stop the pump. Move the bump handle down slowly, then up briskly. Repeat 3 times. Restart the pump and filtration will resume at near the original flow and pressure.

After each regeneration, and until the filter is cleaned, there may be a slight increase in the starting pressure. This is the result of dirt accumulating within the filter and is completely normal.

CLEANING

Cleaning is recommended when the gauge pressure rises more than 10 psi (.70 Bar) in less than a 24 hour period or when cloudy water returns to the pool for more than 30 seconds after regeneration. To clean, first stop the pump; then move the bump handle down slowly, then up briskly. Repeat 8 times. Open the vent valve (under bump cover), open the filter drain (Note: if the filter is installed below the pool water line, close the suction and return valves) and

allow water and-dirt-to-empty completely.

After the filter has drained, and with the drain still open, run the pump for a few seconds to flush out any dirt remaining in the bottom of the filter. (Note: If the filter is installed below the pool water line, opening the *suction* valve for a few seconds with the pump off will adequately flush the unit.)

Close the filter drain and the vent valve. Open the suction and return valves (when used). Start the pump and let the filter fill with water and repeat the CLEANING procedure. This completes the cleaning phase. The filter is now ready for recharging. Proceed as in STARTING THE FILTER and PRECOATING.

VACUUMING

Vacuuming can be performed directly into the filter whenever needed. For fastest results, regenerate the filter before and after each vacuuming operation.

TO CHANGE BUMP HANDLE POSITION

1. Remove the bump handle grip. Push in tab at base of handle. Carefully pry the bump cover from the retaining groove and slide the cover off the handle.
2. Using a drift (or 10 penny nail), tap the pivot pin out of the filter head anchor point, freeing the end of the handle. Rotate the bump handle to the alternate position and align the handle and the head anchor holes. Tap the pivot pin in place.
3. Reinstall the bump cover and grip.

PREVENTIVE MAINTENANCE

While Perflex filters are basically resistant to the difficulties often encountered as a result of chemical build-up in swimming pools, it is important to keep in mind that the mineral content in a pool increases every day as a result of the chemicals and the normal water evaporation process. If the concentration of minerals is allowed to get too high, the minerals will form deposits on the Flex-Tubes inside the filter, and will eventually result in shortened filter cycles. To guard against this, a yearly chemical cleaning (soaking) of the Flex-Tube assembly is suggested. Use commercially available 20% muriatic acid added to water in 1 to 1 ratio; or use other commercial filter element cleaner mixed according to the package instructions. Use a plastic container.

CAUTION: WHEN HANDLING CLEANING AGENTS AS THEY CAN BE HARMFUL TO THE EYES, SKIN AND CLOTHING.

After cleaning, thoroughly flush all affected parts with cold water. Always wear gloves and eye protection when handling cleaning agents.

WINTERIZING

In areas where sub-freezing temperatures can be expected, the filter should be drained and removed from its operating location and stored indoors. Prior to removal, cycle the filter as described under CLEANING.



USE ONLY HAYWARD GENUINE REPLACEMENT PARTS

| REF. NO. | PART NO. | DESCRIPTION | NO. REQ'D. |
|----------|------------|--|------------|
| 1 | ECX11206 | Bump Mechanism Cover | 1 |
| 2 | ECX1019 | Cover Screw (1981 and Prior) | 2 |
| 3 | ECX1322A | Vent Valve With O-Ring | 1 |
| 4 | ECX11194AT | Filter Head with Vent Valve | 1 |
| 5 | ECX100Z9 | Roll Pin | 1 |
| 6 | ECX4236A | Bump Shoulder bolt Kit | 1 |
| 7 | | Nut in bolt Kit | |
| 8 | ECX1040 | Bump Handle Assy w/pins, bolt & nut | 1 |
| 9 | ECX1037B | Bump Handle Grip | 1 |
| 10 | ECX1642A | Tank Bolt Set (Screw and Nut) | 15 |
| 11 | ECX1077 | 1/4" x 1 1/16" OD Flat washer | 30 |
| 12 | ECX1230 | Decal-Operation Instructions | 1 |
| 13 | SPX1500NYA | Tube Sheet Screw | 16 |
| 14 | ECX1110 | Bump Shaft | 1 |
| 15 | ECX9611246 | O-ring | 3 |
| 16 | ECX1014 | Retainer | 2 |
| 17 | ECX1011 | Thrust Washer | 2 |
| | ECX1014A | Shaft kit (Includes 15,16,17) | 1 |
| 18 | ECX1104 | Tube Sheet Top | 1 |
| 19 | ECX1105 | Diaphragm Gasket | 1 |
| 20 | ECX1103 | Tube Sheet Bottom | 1 |
| 21 | SPX1500Y1 | Tube Sheet Nut | 16 |
| 22a | ECX1031 | Flex-Tube Assembly 13 3/8" (EC65) | 120 |
| 22b | ECX1032 | Flex-Tube Assembly 16 1/4" (EC75) | 120 |
| 23 | ECX1642215 | 1/4"-20 x 1 3/4" Hex head Bolt | 16 |
| 24 | SP0723 | Ball-Type Drain Valve with Nipple | 1 |
| 25 | ECX4220A | Elbow Assy w/ Check Valve | 1 |
| 26 | ECX4077B1 | Check Valve | 1 |
| 27 | SPX1500W | O-ring | 1 |
| 28a | ECX27091 | Pressure Gauge | 1 |
| 28b | ECX12866 | Gauge Port Adapter | 1 |
| 28c | ECX1287 | Adapter O-ring | 1 |
| 29 | ECX11184AT | Filter Body w/Internal Elbow | 1 |
| 30 | | Super, Super II™, or Tri-Star™ pump | 1 |
| 31 | SPX1485C | Gasket | 1 |
| 32 | SPX1485B | Pump Discharge Elbow | 1 |
| 33 | SPX1425Z6 | O-Ring | 1 |
| 34 | SPX1485A | Union Ball End | 1 |
| 35 | SPX1480C | Union Nut | 1 |
| 36 | ECX1263 | Platform Base | 1 |
| 37 | ECX1275 | Pump Mounting Screw | 2 |
| 38 | EC1161 | Washer | 2 |
| | ECX12515 | Flex-Tube Nest (EC65) | |
| | ECX125175 | Flex Tube Nest (EC75) (Includes. 13thru 22) | 1 |

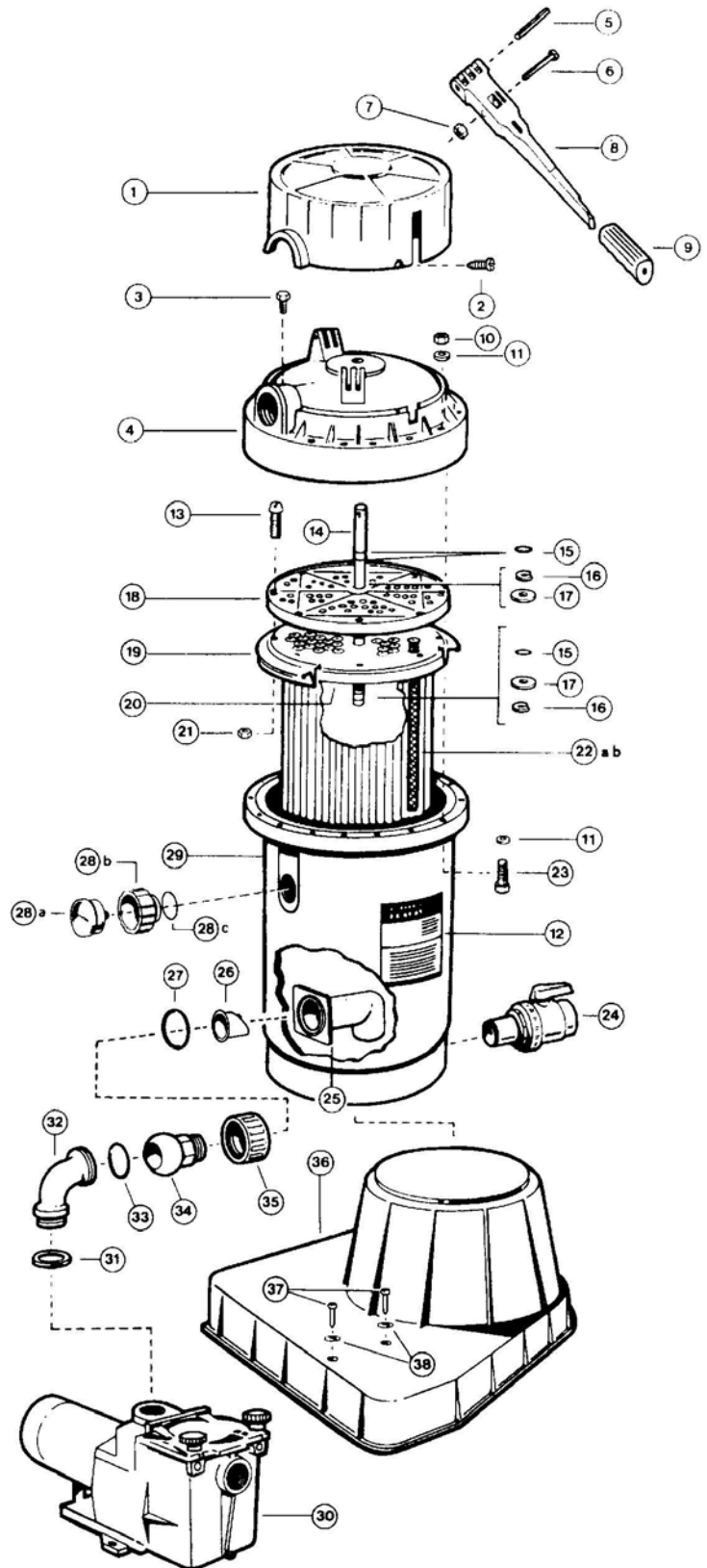

SERVICE & REPAIRS

Consult your local authorized *Hayward-Perflex* dealer or service center. No returns may be made directly to the factory without the expressed written authorization of Hayward Pool Products, Inc.

ALGAE CONTROL

Algae is a form of plant life which can vary in size from a few thousandths of an inch to the size of a small tree. Of the many forms of algae, those most frequently found in swimming pool water are microscopic in size and green in color.

Algae readily grows in sunlight and can, under favorable conditions, quickly overgrow a swimming pool turning it completely green in just a few hours. On the other hand, swimming pool water can be kept unfavorable to algae growth simply by maintaining a chlorine level of at least 0.5 ppm in the water at all times. The chlorine level should be checked at least once a day using a suitable test kit.

If an algae condition develops and the pool water "blooms" green, superchlorination of the pool will be necessary to clear it. Add unstabilized granular chlorine, or liquid chlorine.

Follow chemical manufacturer's recommendation for superchlorination. The algae will quickly become inactive and can then be removed by the filter. Live algae, on the other hand, multiplies so fast that the filter cannot keep up with its growth rate. In an active algae situation, it may be necessary to regenerate the Perflex filter as frequently as every 2 to 3 hours.

When correctly used, commercial algaecides are effective against algae, though algaecides should be used in conjunction with, and not as a substitute for, regular chlorination or superchlorination.

Maintaining a chlorine level of at least 0.5 ppm in the pool water at all times is the most effective way to prevent algae growth in swimming pools.

POOL CHEMISTRY GUIDELINES

| SUGGESTED POOL CHEMISTRY LEVELS | | ACTION REQUIRED TO CORRECT POOL CHEMISTRY | |
|--|----------------|---|---|
| | | TO RAISE | TO LOWER |
| pH | 7.2 to 7.6 | Add Soda Ash | Add Muriatic Acid or Sodium Bisulphate |
| TOTAL ALKALINITY | 100 to 130 ppm | Add Sodium Bicarbonate | Add Muriatic Acid |
| CHLORINE (UNSTABILIZED) | 0.3 to 1.0 ppm | Add Chlorine Chemical | No action - chlorine will naturally dissipate |
| CHLORINE (STABILIZED) | 1.0 to 3.0 ppm | Add Chlorine Chemical | No action - chlorine will naturally dissipate |
| CHLORINE STABILIZER (Cyanuric Acid) | 40 to 70 ppm | Add Stabilizer | Dilution - partially drain & refill pool with water that has not been treated with Cyanuric Acid. |

PRODUCT REGISTRATION

(Retain for Your Records)

DATE OF INSTALLATION _____

PURCHASED FROM _____

MODEL _____

SERIAL NUMBER _____

▲ Retain this Warranty Certificate in a safe and convenient location for your records.

USE ONLY HAYWARD GENUINE REPLACEMENT PARTS

| PROBLEM | PROBABLE CAUSE | REMEDY |
|---|---|---|
| Running at high pressures. | <ol style="list-style-type: none"> 1. D.E. coated with normal accumulation of pool dirt, algae, etc. 2. Overcharge of D.E. 3. Restriction in return line caused by small eyeball fitting. 4. Partially closed valve on return line. | <ol style="list-style-type: none"> 1. Bump. 2. Bump-Drain-Recharge. 3. Change to larger size fitting. 4. Open valve. |
| Drop off of return flow. | <ol style="list-style-type: none"> 1. D.E. coated with normal accumulation of pool dirt, algae, etc. 2. Pump strainer basket clogged. 3. Skimmer basket clogged. 4. Pump impeller vanes clogged. 5. Air leak on suction side of pump. 6. Electric motor running less than maximum R.P.M. (under speed) | <ol style="list-style-type: none"> 1. Bump. 2. Clean. 3. Clean. 4. Cleaning with a stiff wire thru the pump strainer opening will usually work. Alternate would be to disassemble-and clean. 5. Check cover gasket, hand knobs, hose, clamps, etc. Replace or tighten as necessary. 6. Consult pump and motor trouble shooting guide. <p>NOTE: Most motor problems are due to:</p> <ol style="list-style-type: none"> 1. Undersized or improper wiring. 2. Power cut-backs or a combination of both. |
| Short cycles. | <ol style="list-style-type: none"> 1. D.E. loaded to capacity with pool dirt, algae, etc. 2. Bumping incorrectly. 3. Bump handle bent. 4. Pump output exceeds design flow rate of filter. 5. Presence of algae. | <ol style="list-style-type: none"> 1. Bump-Drain-Recharge. 2. Slow down stroke - brisk upstroke. Repeat 6 times. 3. Check and straighten or replace. 4. Check GPM/LPM output. Regulate pump GPM/LPM output to max. filter GPM/LPM rating. 5. Super-chlorinate; Bump-Drain-Recharge as needed. |
| Short cycles -- even after proper bumping, draining, and recharging | <p>Contaminated (clogged) Flex-Tube braids caused by:</p> <ol style="list-style-type: none"> a. Natural accumulation of chemical deposits (accelerated if chemicals are fed thru skimmer). b. Running D.E. charge too long with excessive amount of live algae present in pool. c. Operating filter without D.E. d. Operating too long without D.E. after starting pump. D.E. must be added as soon as filter is full of water and pump is putting out a steady stream. | <p>Clean Tube Nest</p> <ol style="list-style-type: none"> a) Detergent Cleaning: Remove tube nest and hose down with forceful stream of clean water. Soak tube nest in strong solution of laundry detergent (such as <i>Cheer</i>) and warm water. Hose down again. b) Chemical Cleaning: This requires use of water and muriatic acid solution (or filter |

USE ONLY HAYWARD GENUINE REPLACEMENT PARTS

| | | |
|--|--|---|
| | <i>IMPORTANT</i> — Testing a new pool plumbing system without adding D.E. will cause this type of clogging. | cleaner-type preparations) to chemically dissolve contaminates. Consult your pool dealer for chemical cleaning instructions. |
| D.E. leaking to pool via the return lines | <ol style="list-style-type: none"> 1. Opening or tear in one or more Flex-Tubes. 2. Rip or hole in diaphragm gasket. 3. Worn or loose fitting diaphragm gasket (chemicals fed thru suction lines may shorten life of this part). 4. Loose bolts on tube nest plates. | <ol style="list-style-type: none"> 1. Replace Flex-Tube. 2. Replace gasket. 3. Replace gasket. 4. Tighten bolts. |
| Hard bumping. | <ol style="list-style-type: none"> 1. Caking of D.E. under tube sheet. Sometimes caused by accumulation of sun tan oils, hair or floating particles that bind together in a clay-like form. 2. Overloaded with D.E. Sometimes happens when last charge of dirty D.E. was not properly drained. 3. Filter runs too long between bumping. | <ol style="list-style-type: none"> 1. Bump-Drain-Recharge more often and reduce the use of oils. 2. Bump-Drain-Recharge with proper amount of D.E. 3. Bump more frequently. |
| D.E. leaking back to pool via skimmer or main drain. | Filter check valve worn or stuck open. | Clean and/or replace. |
| Very short cycles when vacuuming. | <p>Normal if pool contains:</p> <ol style="list-style-type: none"> 1. Very dirty water. 2. Presence of live, vigorously growing algae. <p>Presence of alum or floccing agents, which will clog filter.</p> | <ol style="list-style-type: none"> 1. Bump-Drain-Recharge more often. 2. Add enough chlorine to control this growth — then vacuum. 3. Vacuum so as to by-pass filter. Avoid using floccing agents. |

USE ONLY HAYWARD GENUINE REPLACEMENT PARTS

HAYWARD® LIMITED WARRANTY

This equipment was inspected before shipment from our plant. To original purchasers of this equipment, Hayward Pool Products, Inc., 620 Division Street, Elizabeth, New Jersey, warrants its products free from defects in materials and workmanship for a period of **ONE (1)** year from the date of purchase.

Parts which fail or become defective during the warranty period, except as a result of freezing, negligence, improper installation, use, or care, shall be repaired or replaced, at our option, without charge, within 90 days of the receipt of defective product, barring unforeseen delays.

To obtain warranty replacements or repair, defective components or parts should be returned, transportation paid, to the place of purchase, or to the nearest authorized Hayward service center. For further Hayward dealer or service center information, contact Hayward customer service department. No returns may be made directly to the factory without the express written authorization of Hayward Pool Products, Inc.

To original purchasers of this equipment, Hayward Pool Products, Inc. warrants its vacuum release systems to be free from defects in materials and workmanship for a period of **ONE (1)** year from the date of purchase.

Filters which become defective during the warranty period, except as a result of freezing, negligence, improper installation, use or care, shall be repaired or replaced, at our option, without charge.

All other conditions and terms of the standard warranty apply.

Hayward shall not be responsible for cartage, removal and/or reinstallation labor or any other such costs incurred in obtaining warranty replacements.

The Hayward Pool Products warranty does not apply to components manufactured by others. For such products, the warranty established by the respective manufacturer will apply.

Some states do not allow a limitation on how long an implied warranty lasts, or the exclusion or limitation of incidental or consequential damages, so the above limitation or exclusion may not apply to you.

This warranty gives you specific legal rights, and you may also have other rights, which vary from state to state.

Hayward Pool Products, Inc.
620 Division Street
Elizabeth, NJ 07207
***Supersedes all previous publications.**

USE ONLY HAYWARD GENUINE REPLACEMENT PARTS

Get the Scoop on Achieving Optimum D.E. Filter Performance with Hayward's D.E. Pre-Measure Scoop!



With Hayward's D.E. Pre-Measure Scoop, you can now accurately measure and add the correct amount of diatomaceous earth powder to your pool filter ensuring optimum performance and crystal clear, sparkling water. Hayward's D.E. Pre-Measure Scoop is the only scoop that provides an exact measure of 1 lb. or 1/2 lb. of D.E. Needless guesswork is eliminated. Adding D.E. is accurate, easy, and fast—all with no mess. The D.E. Pre-Measure Scoop doubles as a broadcaster for distributing granular chlorine to your pool. It can also be used for scooping out those hard-to-remove final gallons of water from your spa. Plus, there are hundreds of other uses. Hayward's D.E. Pre-Measure Scoop is available at your pool dealer. Just look for the bright orange display.

Watch it on Video!

Now that you've got the filter that provides the cleanest, clearest pool water...Get the video that keeps maintenance at a minimum and pool enjoyment at a maximum! That's right. Hayward Pool Products has an easy, stress-free way for you to learn about how to operate and maintain your Perflex filter—by video. The new twelve minute Perflex video includes easy-to-follow *how-to's*, on achieving and maintaining proper pool water chemistry, initial start-up and operation of your Perflex fitter, cleaning your Perflex, plus vacuuming, preventative maintenance, and winterizing. Perflex – the video. It keeps maintenance at a minimum and pool equipment at a maximum!

Just order "Operation and Maintenance" Video Part Number EC-OM-Video-90 and include your check or money order for \$9.95* (+ \$2.50 for shipping and handling) and mail to:

Hayward Pool Products Inc.
620 Division Street
Elizabeth, NJ 07207
Attn: Marketing Communications

DETACH HERE: Fill out completely and mail within 10 days of purchase/installation, or REGISTER ONLINE AT WWW.HAYWARDNET.COM



HAYWARD®

Mail to: Hayward Pool Products, 620 Division Street, Elizabeth, NJ 07207, Attn: Warranty Dept.

Please Print Clearly: Warranty Registration Card

Name _____

Purchased Date: _____

Address _____

Purchased from: _____

City _____ State _____ Zip _____

Company name _____

E-mail Address _____

Address _____

Phone No: _____

City _____ State _____ Zip _____

Product Model Number _____

Please send me more information on these other products from Hayward:

Product Serial No. _____

Pump Filter Automatic Pool Cleaner Light

New Installation Replacement

Chlorinator Skimmer Heater Heat Pump

Type of In-Ground Pool:

Salt/Chlorine Generator Controls

Vinyl Fiberglass Gunite

May we contact you for future product promotions and offerings? Yes No

Size of Pool _____

© Hayward Pool Products 2007 REGISTER YOUR WARRANTY ON-LINE AT WWW.HAYWARDNET.COM

All rights reserved.

USE ONLY HAYWARD GENUINE REPLACEMENT PARTS



Pomona, CA Clemmons, NC Nashville, TN
www.haywardpool.com

THIS PAGE IS INTENDED TO BE BLANK

USE ONLY HAYWARD GENUINE REPLACEMENT PARTS