

OWNER'S MANUAL



 **Polaris[®] 3900** SPORT

IMPORTANT INFORMATION

SERIAL NUMBER

Important Information

- Before installing the cleaner, make sure the pool filter is clean.
- New plumbing lines should be flushed out before installing the cleaner.
- The Polaris® should not be used to remove plaster dust in new pools.
- Except when checking the wheel RPM, do not handle the Polaris® while it is operating.
- Always remove the cleaner **before swimmers enter the pool**.
- Disconnect the cleaner before cleaning or backwashing the pool filter. After cleaning, let the filtration system run for at least five minutes before re-connecting the cleaner.
- Always remove the Polaris® from the pool before chemical shock treatments.

For customer service or support:

- Please mail Warranty Card immediately.
- For on-line support: www.polarispool.com
- To contact Polaris: **US and Canada**
2620 Commerce Way
Vista, CA 92081-8438
1-800-822-7933

Polaris® 3900 Sport Limited Warranty

This one year limited warranty is extended to the original consumer purchaser of this Polaris® 3900 Sport Automatic Pool Cleaner manufactured by Zodiac Pool Systems, Inc., ("Zodiac") from date of manufacture of the unit as established by the serial number, or one year from date of purchase with proof of purchase, whichever is later. Zodiac warrants this product, including all parts and components thereof, to be free of defects in material and workmanship. Normal replacement items such as bags, tires, sweep hoses or sweep hose scrubbers which have been worn out by use or improper installation are not covered by this warranty. The Polaris® 3900 Sport frame is warranted for a period of ten years.

This limited warranty does not apply if the failure is caused or contributed to by any of the following: improper handling, improper usage, improper storage, winter freezing, abuse, improper installation, removal of the in-filter screen, unsuitable application of the unit, improper maintenance, lack of reasonable and necessary maintenance, damage in transit or during installation, or damage from repairs/alterations made or attempted by anyone other than Zodiac or one of its Authorized Service Centers. **IN NO EVENT SHALL ZODIAC BE LIABLE FOR INCIDENTAL OR CONSEQUENTIAL DAMAGES OF ANY NATURE OR FOR DAMAGES TO PERSONS OR PROPERTY, INCLUDING ANY DAMAGES TO VINYL LINERS, PLASTER, TILE, AGGREGATE-BASED AND OTHER POOL SURFACES, OR DAMAGES RESULTING FROM THE USE OF THIS PRODUCT WITH A SUBSTANDARD POOL CIRCULATION SYSTEM OR A CHEMICAL IMBALANCE.**

Authorization to return a unit or part to the plant of manufacture must be obtained from the Zodiac Customer Service Department. Check with your dealer for the local procedure before exercising this warranty. If further directions or instructions should be required, contact the Customer Service Department at 1-800-822-7933 (USA and Canada only) or (760) 599-9600. Be sure to insure the shipment against loss or damage in transit.

This limited warranty is valid only in the United States of America, Mexico and Canada, and it does not apply to Polaris® 3900 Sport Automatic Swimming Pool Cleaners sold or installed in any other country.

WARNING: USE OF THE POLARIS® IN A VINYL LINER POOL

Certain vinyl liner patterns are particularly susceptible to rapid surface wear or pattern removal caused by objects coming into contact with the vinyl surface, including pool brushes, pool toys, floats, fountains, chlorine dispensers, and automatic pool cleaners. Some vinyl liner patterns can be seriously scratched or abraded simply by rubbing the surface with a pool brush. Ink from the pattern can also rub off during the installation process or when it comes into contact with objects in the pool. Zodiac Pool Systems, Inc. is not responsible for, and the Limited Warranty does not cover, pattern removal, abrasion or markings on vinyl liners.

Introduction

Congratulations on the purchase of your new automatic pool cleaner, and thank you for choosing Polaris®. The Polaris® 3900 Sport is designed to give you years of dependable and efficient service.

Like most mechanical devices, it will require periodic adjustments, routine maintenance, and the replacement of certain hardworking parts. Please have your cleaner checked occasionally by your local Polaris® dealer or authorized service center.

Always insist on genuine Polaris® replacement parts. Non-Polaris® parts are not made to our specifications. They may have an adverse effect on the operation of your Polaris® or may even damage it.

For best results, the cleaner should be installed by a pool professional. For those with experience and confidence in handling plumbing and mechanical equipment, installation is outlined in this manual.

Polaris® 3900 Sport Components

1. SuperBag, (Double) All-Purpose Zippered Bag
2. Cleaner Body
3. Float
4. Sweep Hose
5. Sweep Hose Scrubber
6. Feed Hose
7. Hose Floats
8. Back-up Valve
9. Feed Hose Connector
10. In-Line Filter with Filter Screen
11. Quick Disconnect with Universal Wall Fitting
12. UWF Restrictor Disks, Red and Blue

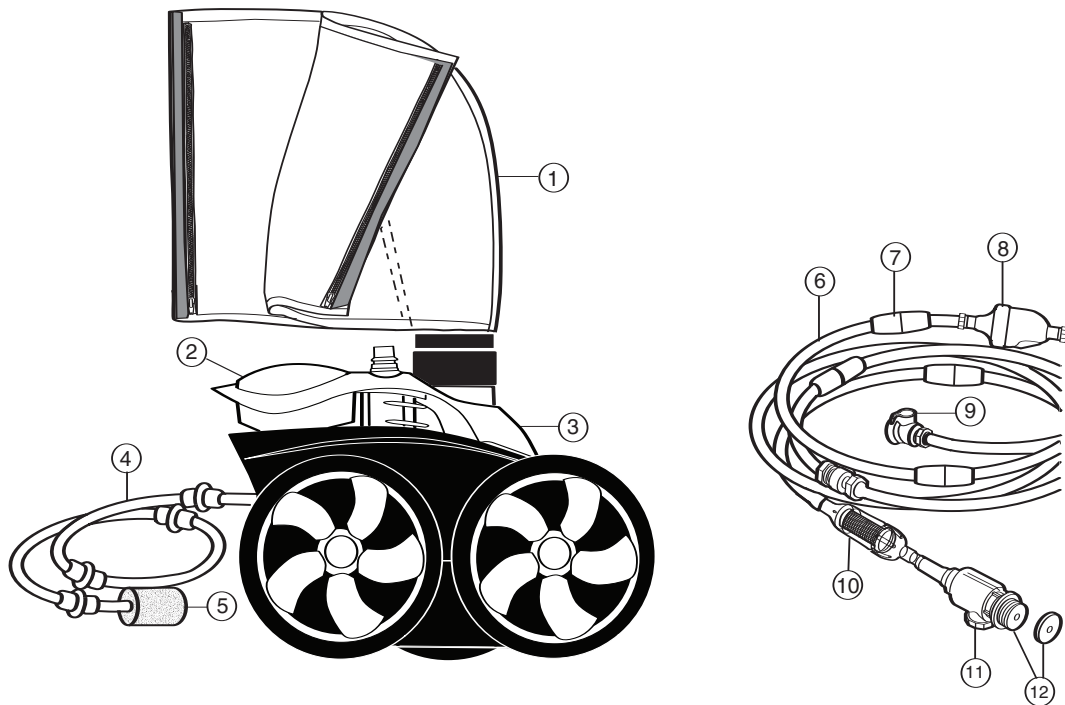

Quick Installation Instructions

1

Install the Universal Wall Fitting

Installs in minutes on pools with a dedicated cleaner return line.

1. Turn on the filtration pump and flush out the plumbing line. Turn pump off.
2. Remove the Universal Wall Fitting (UWF) from the Quick Disconnect and screw it into the return opening with the blue restrictor disk in place.
3. Turn the Quick Disconnect clockwise into the UWF and pull away to secure.

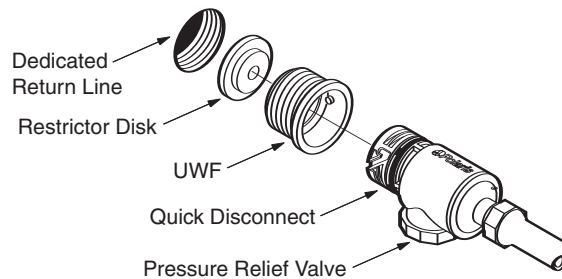

2

Adjust Feed Hose To Fit Pool Length

1. Measure the deepest part of the pool. Cut leader hose, from end that attaches to feed hose, so length is equal to the greatest depth of the pool.
2. Attach leader hose to feed hose and connect hose to the pool wall at the return line. Extend hose to farthest point of pool. The hose end must be within 6" – longer or shorter – of the farthest point. See diagram below.

If hose is too long: Separate hose at center swivel. Cut equal amounts of the overage from each 10-foot feed hose section.

If hose is too short: Add a feed hose section (part #9-100-3104), a swivel (part #D20) and two hose nuts (part #D15). Adjust to proper length.

Each feed hose section should be equal in length after adjustments.

3. After adjusting the length, position the hose floats as shown.

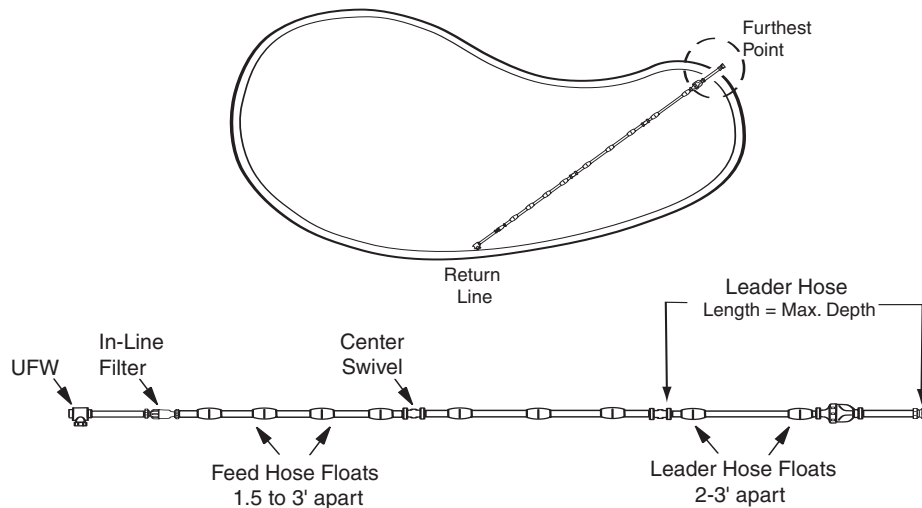

3

Assemble the Cleaner

1. Attach the feed hose connector to the feed pipe by pressing it down firmly until it locks.
2. The filter bag is packaged in the collar area on the vacuum tube. Pull out bag. Wrap bag around hose and secure with Velcro strips.
3. Turn on the pool filtration pump and allow it to prime before turning on the booster pump.

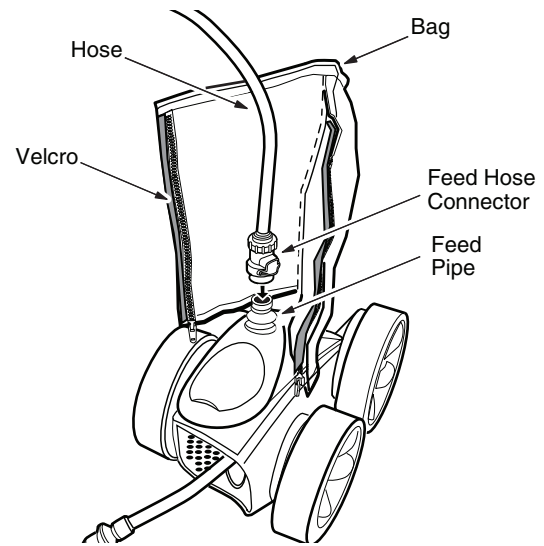

4

Check for Proper RPM

Before operating the Polaris®, check for proper wheel revolutions per minute (RPM). For maximum efficiency, the cleaner should operate **between 30 and 36 RPM**.

1. Mark the single-wheel side tire.
2. Turn pump on, hold cleaner below water level and count wheel revolutions for one minute.

If count is not in target range, refer to ***Adjusting the Wheel RPM*** in the Troubleshooting section for more information.

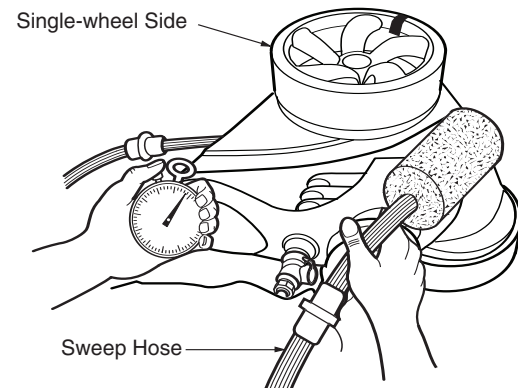

Fine Tuning The Cleaner

When operating correctly, the cleaner vacuums, sweeps and scrubs all surfaces randomly throughout the pool. Approximately every three minutes the cleaner goes into back-up mode. This action pulls the cleaner away from pool obstacles and increases its random pattern.

Thrust Jet Adjustment

The thrust jet powers the direction of the cleaner. Factory position is seven o'clock but, depending on the pool, other settings can be helpful to improve cleaner coverage.

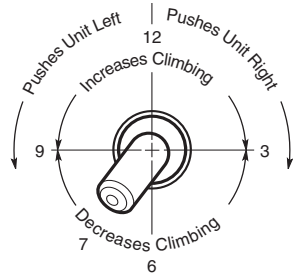

Sweep Hose Adjustment

The sweep hose should move in a gentle sweeping motion. To adjust the motion, turn off the booster pump and turn the sweep jet clockwise to increase or counter-clockwise to decrease the movement.

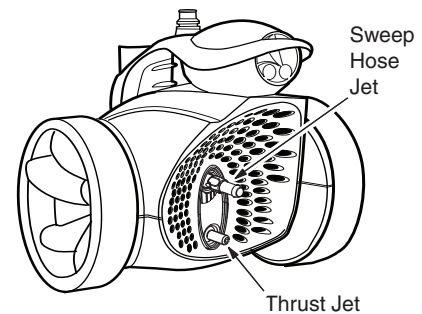

Routine Maintenance

Cleaning the Bag

Detach the Velcro strips. Twist the bag collar and pull up to free the bag from the cleaner. Unzip both sides of the bag to remove the debris.

- Empty the filter bag when it is half full, especially if the debris load is sand.
- It is easier to empty the filter bag when it is dry. Alternate between two bags.

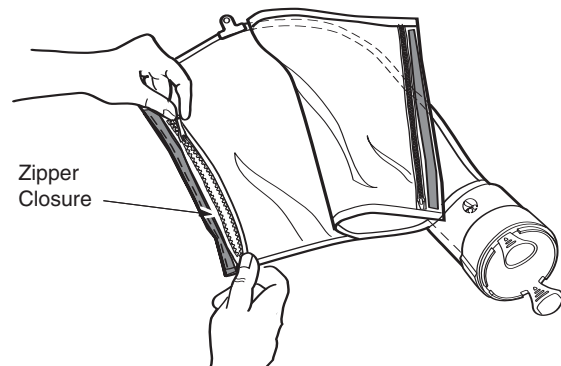

Cleaning the Filters

Always disconnect the Polaris® before cleaning or backwashing the pool filter, and let the filtration system run for at least five minutes before re-connecting the cleaner.

To clean the in-line filter screen, pull it out of the filter assembly, rinse it and press it firmly back into place.

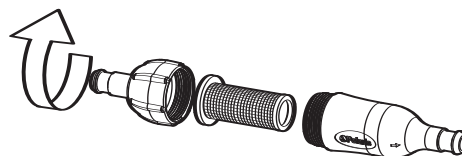

Storage and Winterizing

Never store the cleaner in direct sunlight.

When storing for the winter, drain all the water from the cleaner (freeze damage is not covered under the warranty). Use the Quick Disconnect to remove the UWF from the pool wall. If necessary, use the UWF Removal Tool (part #10-102-00) available from any authorized Polaris® dealer.

Polaris® 3900 SPORT

Exploded Parts Diagram

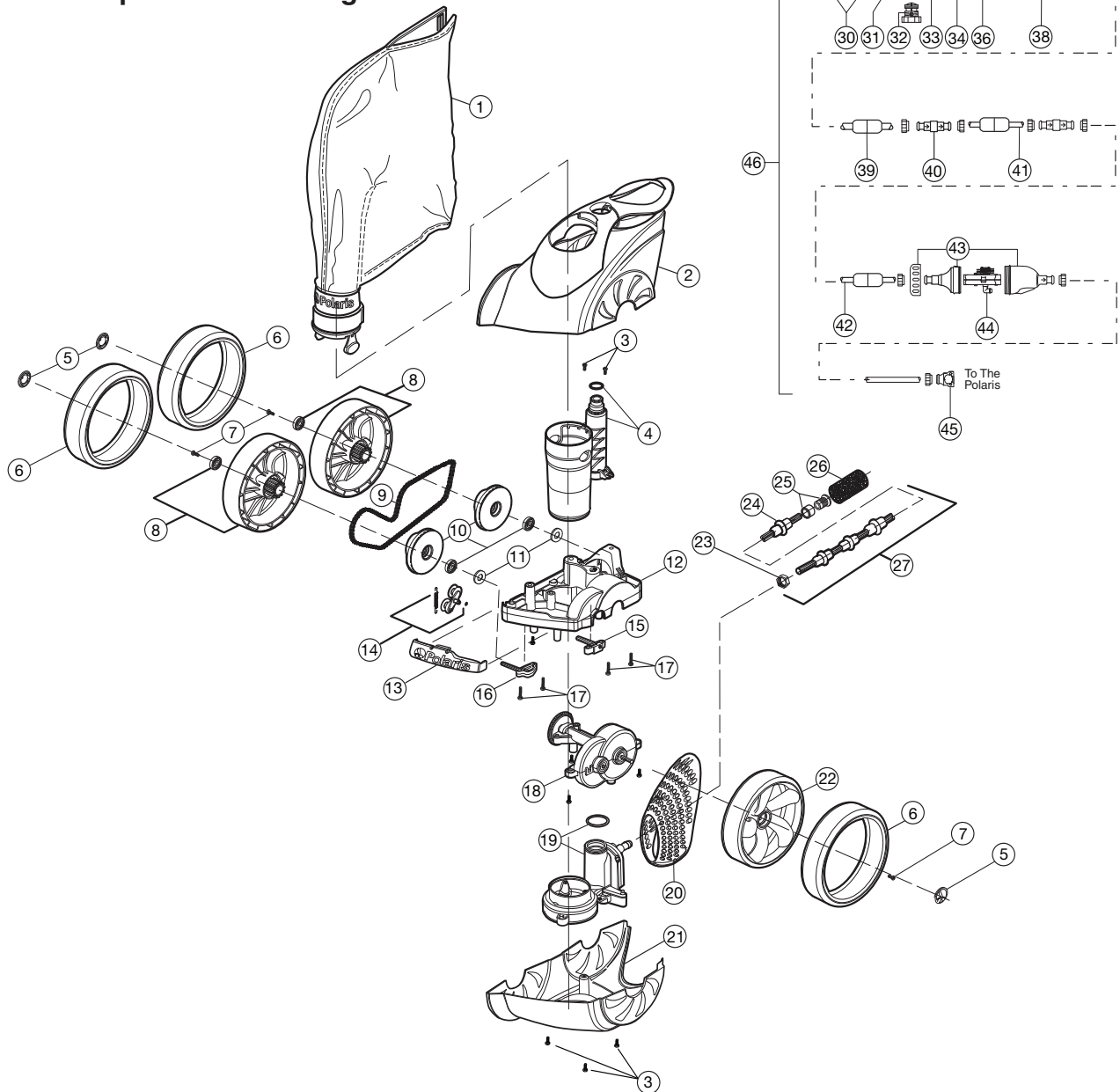

No.	Part	#Description	Qty	No.	Part	#Description	Qty	No.	Part	#Description	Qty
1	39-310	3900 Sport SuperBag*	1	16	39-440	Front Axle Block Assy	1	32	9-100-9002	Pressure Relief Valve, Black	1
2	39-003	Top Housing Assembly	1	17	48-045	Screw, 10-32 x 7/8" SS	4	33	D29	Quick Disconnect, UWF	1
3	C40	Pan Head	19	18	39-200	Gearbox Assembly	1	34	D15	Nut, Feed Hose, Gray	10
4	39-006	Vacuum Tube/Feedpipe Assy with O-Ring	1	19	39-300	WMS Assembly with O-Ring	1	35	9-100-9001	UWF Connector Assembly	1
5	39-008	Hubcap	3	20	39-005	Rear Housing	1	36	D44	Adapter Hose, 8-1/2"	1
6	48-232	WideTrax® Tire, Black*	3	21	39-004	Bottom Housing	1	37	48-080	In-line Filter Assembly	1
7	48-036	Wheel Lock Screw	3	22	39-401	Single-Side Wheel	1	38	48-222	Screen, In-line Filter	1
8	39-410	Double-Side Wheel w/Bearing	2	23	48-219	Nut, Sweep Hose	1	39	D10	Float, Feed Hose, Gray	9
9	39-126	Chain	1	24	39-021	Sweep Hose Wear Ring, Blue*	8	40	D20	Swivel Ball Bearing, Gray	3
10	39-420	Wheel Sprocket Assy w/Bearing	2	25	B25	Orifice Tip w/ Orifice Tip Guard	1	41	D45	Feed Hose, 10 ft., Gray	2
11	39-602	Wheel Spacer	2	26	9-100-3105	Sweep Hose Scrubber*	1	42	D50	Feed Hose, 10 ft., Gray	1
12	**	Frame	1	27	39-500	Sweep Hose Complete*	1	43	G52	Back-up Valve Kit	1
13	39-111	Bumper	1	28	10-112-00	UWF Restrictor Disk, Red & Blue 2	1	44	G53	Mechanism for G52	1
14	39-120	Chain Tensioner Kit	1	29	10-108-00	UWF	1	45	48-140	Feed Hose Connector Assembly	1
15	39-430	Rear Axle Block Assy	1	30	6-500-00	UWF Restrictor Kit	1	46	G5	Feed Hose Assembly Complete	1
				31	6-505-00	O-Ring, UWF	1				

*Wear items not covered by warranty.

Troubleshooting

If the cleaner regularly displays any of the following actions, adjustments may be necessary to restore performance. Refer to the exploded parts diagram for part references.

Action: Cleaner hangs up on steps or other obstacles for longer than 3 minutes.

- Solution:
1. Check the wheel RPM.
 2. Verify the back-up valve is cycling. Lift the valve out of the water and watch the jet. It should come on and go off.
 3. Adjust the thrust jet.
 4. Remove unnecessary pool hardware or install a Ladder Guard Kit (part #G21).

Action: Cleaner is sluggish, running with less power than normal.

- Solution:
1. Check the filter screen in the in-line filter assembly and clean if necessary.
 2. Clean the skimmer basket, pump basket, and pool filter.
 3. Check the hoses, hose connections, and swivels for leaks that could cause loss of water pressure.
 4. Check the wheel RPM. If below 30 RPM, see **Adjusting the Wheel RPM** to increase flow to cleaner.

Action: Cleaner races around the pool and/or does not make contact with the pool bottom.

- Solution:
1. Check the wheel RPM. If more than 36 RPM, see **Adjusting the Wheel RPM** to reduce flow.
 2. Verify the back-up valve is cycling. Lift the valve out of the water and watch the jet. It should come on and go off.

Action: Cleaner doesn't back up.

- Solution:
1. Verify the back-up valve is cycling. Lift the valve out of the water and watch the jet. It should come on and go off.
 2. Check the wheel RPM. If not in 30-36 RPM range, see **Adjusting the Wheel RPM**.
 3. If the filter bag is full, empty or replace it.
 4. Make sure feed hose is floating.

Action: Cleaner only turns in one direction.

- Solution:
1. Adjust the thrust jet.
 2. Make sure feed hose is floating.

Action: Feed hose becomes tangled.

- Solution:
1. Remeasure the hose to verify that it is adjusted to the proper length for the pool.
 2. With the cleaner operating, check that the swivels and hose connections turn freely.
 3. Make sure the feed hose is floating.
 4. With the Polaris® operating, hold the cleaner under water and verify that all three wheels are turning together.

Action: The front end of the cleaner lifts all the time.

- Solution:
1. Check the wheel RPM. If not in 30-36 RPM range, see **Adjusting the Wheel RPM**.
 2. Adjust the thrust jet downward.
 3. Verify the back-up valve is cycling. Lift the valve out of

the water and watch the jet. It should come on and go off.

4. Check for water inside the cleaner float.

Action: Sweep hose is sucked into the vacuum tube.

- Solution:
1. Make sure the opening at the end of the sweep hose is not blocked by the sweep hose scrubber. Replace scrubber if it is worn or missing.
 2. Adjust the sweep hose to a gentle sweeping motion.
 3. Check the wheel RPM. If more than 36 RPM, see ***Adjusting the Wheel RPM*** to reduce flow.
 4. Add a sweep hose weight (part #B2).

Action: Sweep hose sprays too much water out of the pool.

- Solution:
1. Adjust the speed of the sweep hose.
 2. Pull the sweep hose scrubber down to cover more of the tip of the hose.
 2. Replace the scrubber if it is worn or missing.
 3. Add a sweep hose weight (part #B2).

Action: The cleaner does not clean the entire pool.

- Solution:
1. Verify that feed hose reaches within 6" of the farthest point of the pool. If not, order a new hose section from your Polaris® dealer.
 2. Adjust thrust jet to improve coverage.

Action: The cleaner is running in circles on its side.

- Solution:
1. Check for water inside the cleaner float.
 2. Check the filter bag, if full it can weigh the cleaner down on one side.
 3. Check the hose floats to make sure they are spaced evenly.
 4. Check the wheel RPM. If more than 36 RPM, make adjustments to reduce flow.

Adjusting the wheel RPM:

If count is **less than 30 RPM**:

- If an adjustable valve is installed on the cleaner line, open it completely so water can flow freely to the Polaris®.
- Check the filter screen in the in-line filter for debris that restricts water flow.
- Clean the skimmer, filter and pump basket, clearing debris that restricts water flow.
- Check the hoses, connections and swivels for leaks that cause loss of water pressure.
- Remove the blue restrictor disk from the UWF.

If count is **more than 36 RPM**:

- Replace the blue restrictor disk in the UWF with the red restrictor. If the flow is still too high, unscrew the pressure relief valve until the proper RPM is reached. Note: The pressure relief valve should only be adjusted when a restrictor is installed.
- If an adjustable valve is installed on the cleaner line, adjust it to reduce the water flow to the cleaner.



2620 Commerce Way, Vista, CA 92081-8438 • 760-599-9600 • 1-800-822-7933

www.polarispool.com